

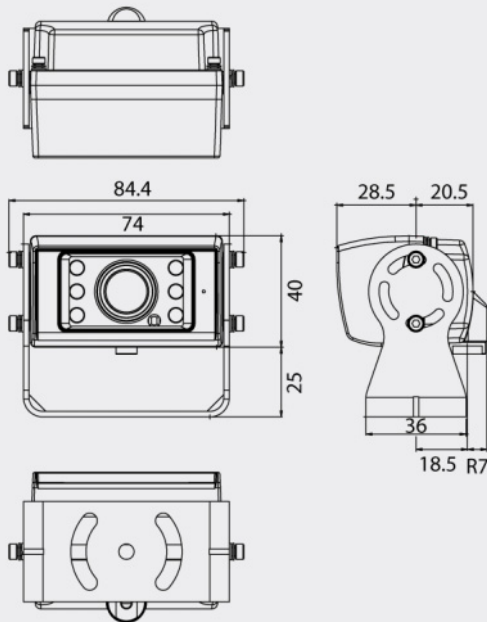

### Features

- 1/3 inch IT CCD
- High Resolution : 420 TV Lines
- Built in Fixed Lens (f=2.7mm, View Angle: 130°)
- Built-in IR LEDs (6EA)
- **Intelligent IR Technology**
- Min. Illumination : 0.00 Lux (IR LED On)
- Auto White Balance
- Audio Function
- IP67
- 12VDC

### DIMENSIONS



### SPECIFICATIONS

Model	RCL-10S	RCL-11S
Signal System	NTSC	PAL
Scanning System	2:1 Interlace	
Scanning Frequency (H)	15.734 KHz	15.625 KHz
Scanning Frequency (V)	59.94 Hz	50 Hz
Image Sensor	1/3 Inch IT CCD	
Total Pixels	537 (H) x 505 (V) 270K	537 (H) x 597(V) 320K
Effective Pixels	510 (H) x 492 (V) 250K	500 (H) x 582 (V) 290K
Horizontal Resolution	420 TV Lines	
Video Output	1.0V p-p (75Ω, Composite)	
Audio Output	2V p-p	
S/N Ratio	More than 50dB (AGC Off)	
Lens	Built-in Fixed Lens (f=2.7mm, View Angle: 130°)	
Min. Illumination	Day (0.05 Lux), Night (0.00 Lux, IR LED On)	
IR LED and Sensor	<b>Intelligent IR Technology</b> , IR LED (850nm, 80°) 6EA	
IR LED Visible Range	Max. 5m	
White Balance	Auto	
Shutter Speed	1/60~1/120,000 Sec.	1/50~1/120,000sec.
Supplied Voltage	DC10V~15V (Recommendation DC12V±0.5V)	
Power Consumption	Max. 170mA/2W	
Dimensions (WxHxD)	84.4 x 65.0 x 49mm	