

Features

- 1/3 inch Sony Super HAD CCD
- High Resolution : 380 TV Lines
- Built in DC Iris Vari-focal Lens (f=4~9mm)
- Auto White Balance
- AGC, BLC, Flickerless (On/Off)
- Min. Illumination : 0.1 Lux

DIMENSIONS

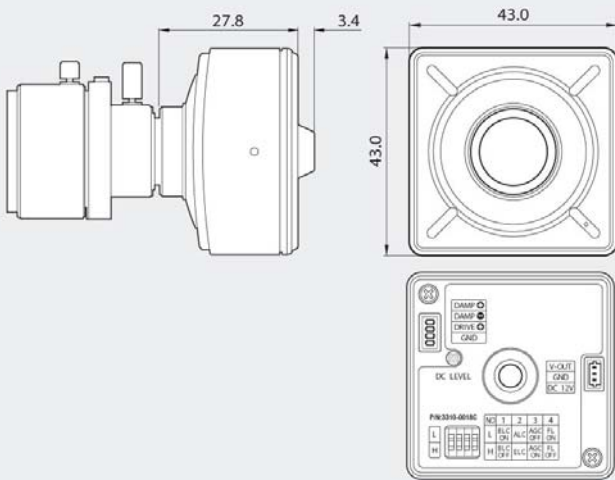

SPECIFICATIONS

Model	CNB-MN258VD	CNB-MP258VD
Signal System	NTSC	PAL
Scanning System	2:1 Interlace	
Scanning Frequency (H)	15.734 KHz	15.625 KHz
Scanning Frequency (V)	59.94 Hz	50 Hz
Image Sensor	1/3 Inch SONY Super HAD CCD	
Total Pixels	537(H) x 505(V) 270K	537(H) x 597(V) 320K
Total / Effective Pixels	510(H) x 492(V) 250K	500(H) x 582(V) 290K
Horizontal Resolution	380 TV Lines	
Video Output	1.0V p-p (75Ω, Composite)	
S/N Ratio	More than 48dB(AGC Off)	
Lens	DC Iris Vari-focal Lens (f=4~9mm)	
Min.Illumination	0.1 Lux	
White Balance	Auto	
AGC,BLC,Flickerless	On/Off Selectable	
Shutter Speed	1/60~1/100,000 Sec.	1/50~1/100,000sec.
Supplied Voltage	DC9V~15V (Recommendation DC12V±0.5V)	
Power Consumption	Max. 3W	
Dimensions(WxH)	43.0x43.0 mm	